

Quick Start Guide

GNSS expansion board based on Teseo-LIV3F module for STM32 Nucleo
(X-NUCLEO-GNSS1A1)

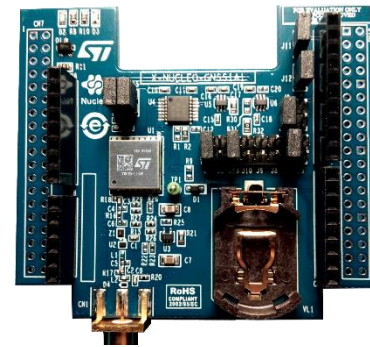

Version 2.0 (May 11, 2018)

Quick Start Guide Contents

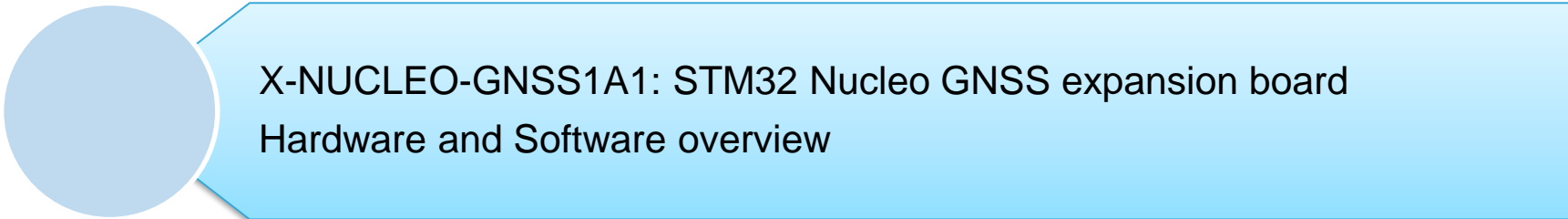

X-NUCLEO-GNSS1A1: STM32 Nucleo GNSS expansion board
Hardware and Software overview



Setup & Demo Examples
Documents & Related Resources



STM32 Open Development Environment: Overview

GNSS expansion board Hardware Overview

3

X-NUCLEO-GNSS1A1 Hardware Description

- The X-NUCLEO-GNSS1A1 expansion board is based on the Teseo-LIV3F tiny GNSS module.
- It represents an affordable, easy-to-use, global navigation satellite system (GNSS) module, embedding a Teseo III single die standalone positioning receiver IC, usable in different configurations in your STM32 Nucleo project.
- The Teseo-LIV3F is a compact (9.7x10.1 mm) module that provides superior accuracy thanks to the on-board 26 MHz temperature compensated crystal oscillator (TCXO) and a reduced time-to-first fix (TTFF) with its dedicated 32 KHz real-time clock (RTC) oscillator.
- The Teseo-LIV3F module runs complete GNSS firmware (X-CUBE-GNSS1) to perform all GNSS operations including acquisition, tracking, navigation and data output without external memory support.
- The X-NUCLEO-GNSS1A1 expansion board is compatible with the Arduino™ UNO R3 connector and the ST morpho connector, so it can be plugged to the STM32 Nucleo development board and stacked with additional STM32 Nucleo expansion boards.

Key Products on board

Teseo-LIV3F: Single die standalone positioning receiver IC working on multiple constellations, 10x10mm compact size.

26MHz Temperature Compensated Crystal Oscillator (TCXO) and reduced Time To First Fix (TTFF) relying to a 32KHz Real Time Clock (RTC) oscillator for superior accuracy.

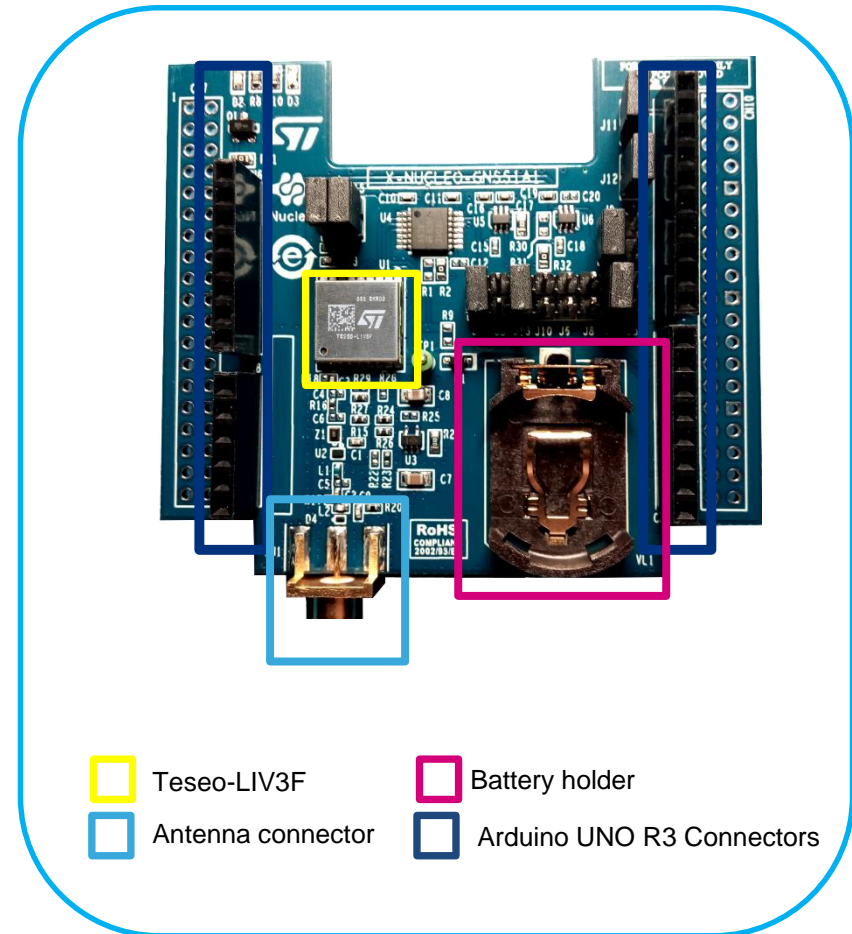

- Teseo-LIV3F
- Battery holder
- Antenna connector
- Arduino UNO R3 Connectors

Latest info available at www.st.com
X-NUCLEO-GNSS1A1

GNSS expansion board

Software overview

4

X-CUBE-GNSS1 software description

- The X-CUBE-GNSS1 expansion package for STM32Cube runs on STM32 and includes drivers for the Teseo-LIV3F global navigation satellite system (GNSS) device as well as middleware for the NMEA protocol support and FreeRTOS for task scheduling ensuring better asynchronous message parsing.
- It is built on top of STM32Cube software technology for easy portability across different STM32 microcontrollers.
- The software comes with sample implementations for the drivers running on the X-NUCLEO-GNSS1A1 expansion board, when connected to a NUCLEO-F401RE, NUCLEO-L476RG, or NUCLEO-L073RZ board.

Key features

- Complete software to build applications using Teseo-LIV3F GNSS device
- Middleware for the NMEA protocol support
- FreeRTOS task scheduling
- Sample application to transmit GNSS data to a PC
- Easy portability across different MCU families, thanks to STM32Cube
- Free, user-friendly license terms



Overall Software Architecture

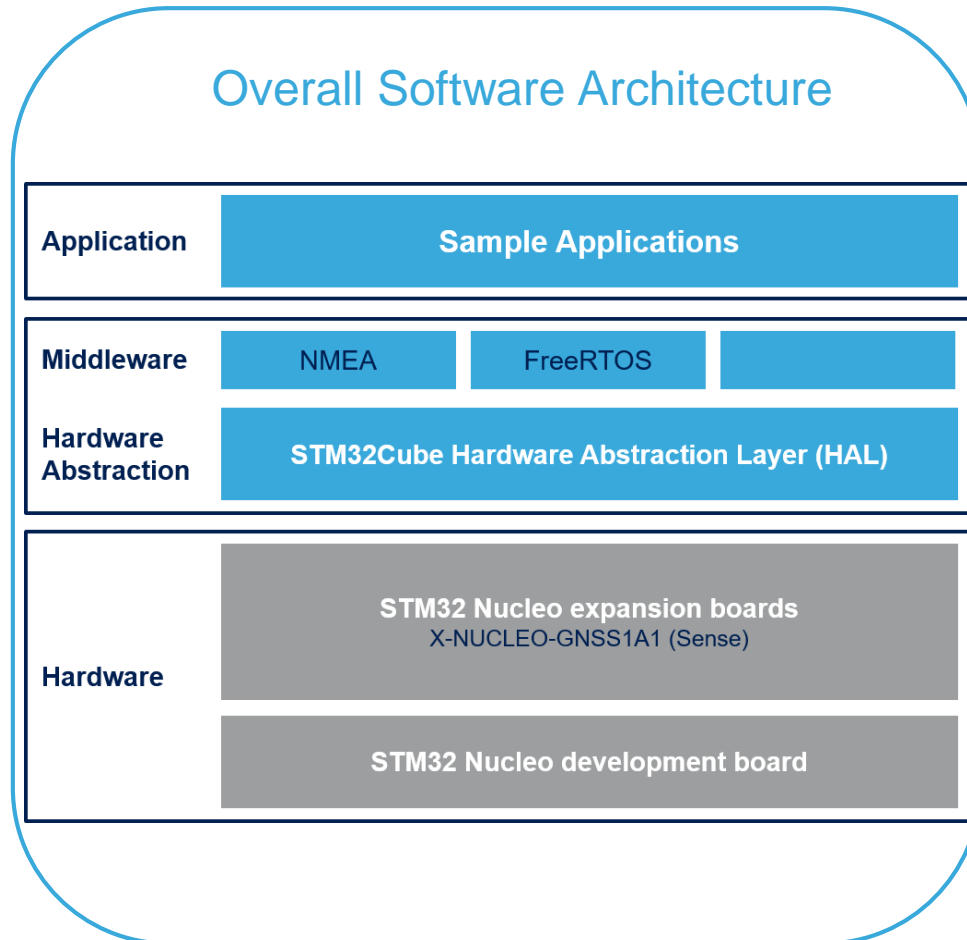

Latest info available at www.st.com

X-CUBE-GNSS1

Quick Start Guide Contents

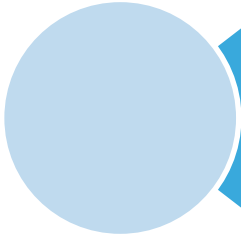

X-NUCLEO-GNSS1A1: STM32 Nucleo GNSS expansion board
Hardware and Software overview

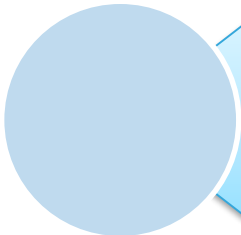

Setup & Demo Examples
Documents & Related Resources



STM32 Open Development Environment: Overview

Setup & demo examples

HW prerequisites

6

- 1 x STM32 Nucleo GNSS expansion board (X-NUCLEO-GNSS1A1)
- 1 x STM32 Nucleo development board (NUCLEO-F401RE / NUCLEO-L476RG / NUCLEO-L073RZ)
- 1x Laptop/PC with Microsoft Windows 7 (or above)
- 1x GPS/GLONASS/Beidou Antenna
- 1x USB type A to Mini-B USB cable

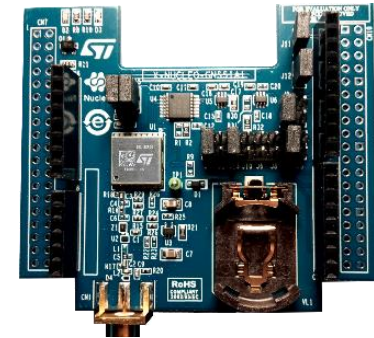
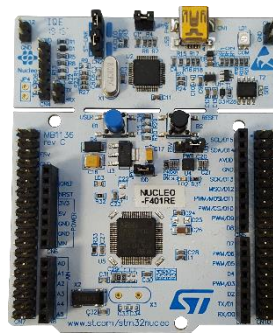

Setup & demo examples

SW prerequisites

7

- **STSW-LINK009**: ST-LINK/V2-1 USB driver
- **STSW-LINK007**: ST-LINK/V2-1 firmware upgrade
- **X-CUBE-GNSS1**: expansion software for STM32Cube
 - Copy the .zip file content into the “c:\Program Files (x86)\STMicroelectronics\” folder on your PC
 - The package contains the source code examples (Keil, IAR EWARM, System Workbench for STM32) based on NUCLEO-F401RE

Global Navigation Satellite System expansion board

Start coding in just a few minutes with X-CUBE-GNSS1

1 Go to www.st.com/x-nucleo

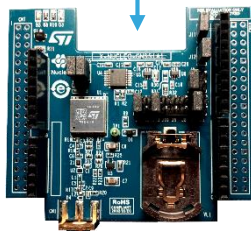

2 Select X-NUCLEO-GNSS1A1

3 Download and unpack X-CUBE-GNSS1

X-CUBE-GNSS1 package

- _htmresc
- Documentation ← Generic Nucleo docs & GNSS porting
- Drivers ← GNSS UART and I2C drivers
- Middlewares ← NMEA & FreeRTOS Libraries
- Projects ← Application examples
- Utilities
- Release_Notes.html

4 Download and install STM32 Nucleo ST-LINK/V2-1 USB driver

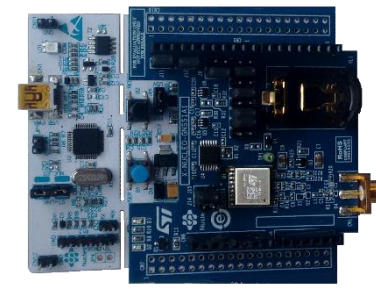

5 Open project example GetPos

6 Modify and build application

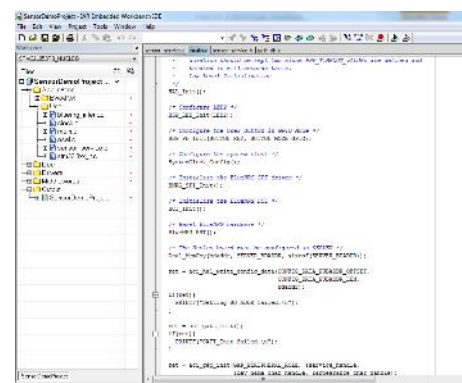

GNSS expansion board

Evaluate using X-CUBE-GNSS1 (1/2)

1

- Connect the STM32 Nucleo board and the X-NUCLEO-GNSS1A1 expansion board
- Connect the GPS/GLONASS antenna to the connector on the X-NUCLEO-GNSS1A1 expansion board
- Connect the STM32 Nucleo board to your PC

2

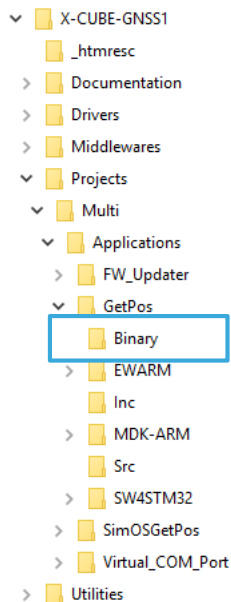

From X-CUBE-GNSS1 software resource package drag and drop **GetPos_*.bin** (in Binary folder) on Nucleo drive

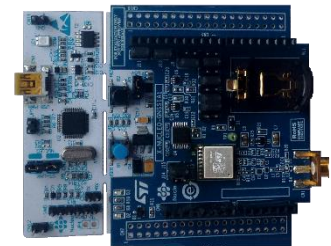
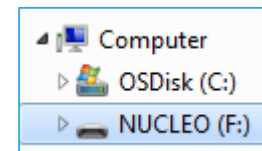

Global Navigation Satellite System expansion board Evaluate using X-CUBE-GNSS1 (2/2)

- 3 Run a Serial Terminal (e.g. TeraTerm) on your PC and open a serial connection

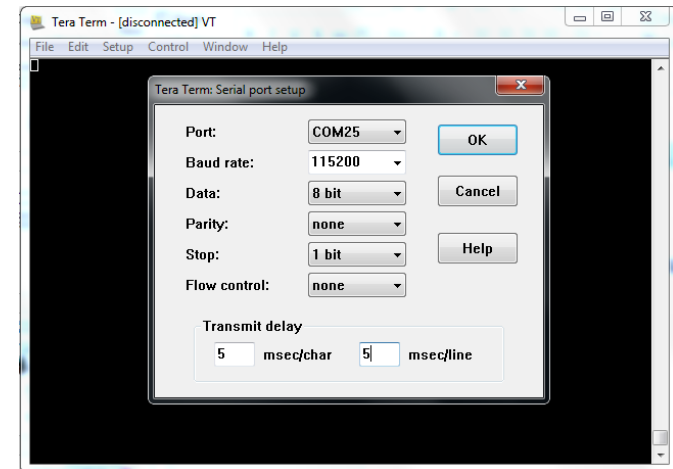

- 4 Reset the STM32 Nucleo board and select an option from the menu appearing on Serial Terminal

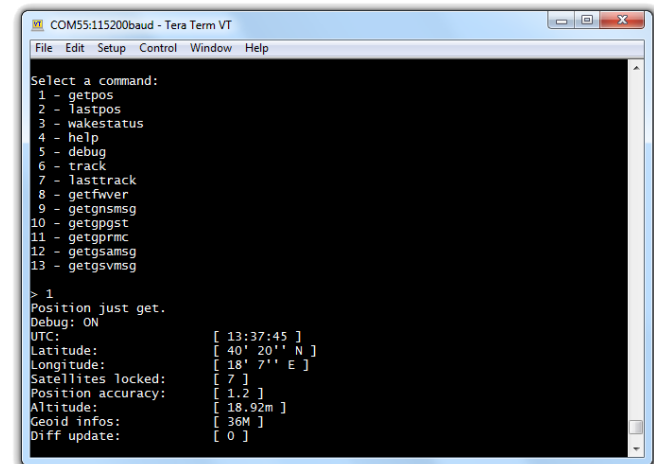
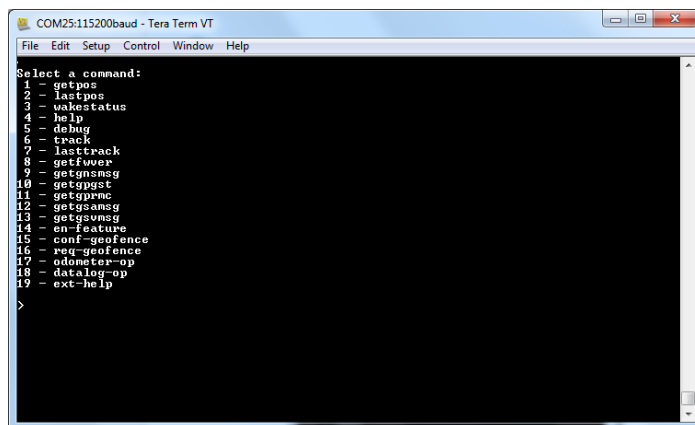

Update Teseo-LIV3F FW using X-CUBE-GNSS1 (1/2)

1

- Connect the STM32 Nucleo board and the X-NUCLEO-GNSS1A1 expansion board
- Connect the STM32 Nucleo board to your PC
 - Note: This application has been tested on Nucelo-F401RE only

2

- ▼ X-CUBE-GNSS1
 - _htmresc
 - > Documentation
 - > Drivers
 - > Middlewares
 - ▼ Projects
 - ▼ Multi
 - ▼ Applications
 - ▼ FW_Updater
 - Binary
 - > EWARM
 - Inc
 - > MDK-ARM
 - Src
 - > SW4STM32
 - > GetPos
 - > SimOSGetPos
 - > Virtual_COM_Port
 - > Utilities

From X-CUBE-GNSS1 software resource package drag and drop FW_Updater-*.bin (in Binary folder) on Nucleo drive

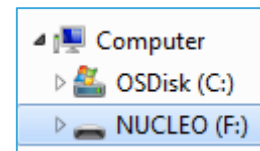

Update Teseo-LIV3F FW using X-CUBE-GNSS1 (2/2)

3

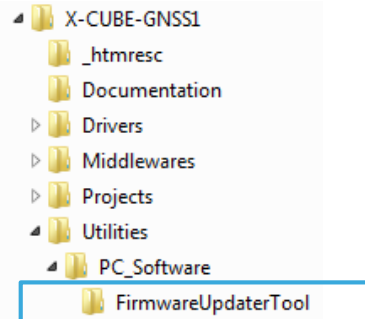

From X-CUBE-GNSS1 software resource package open the java tool FWUPG.jar (in FirmwareUpdaterTool folder)

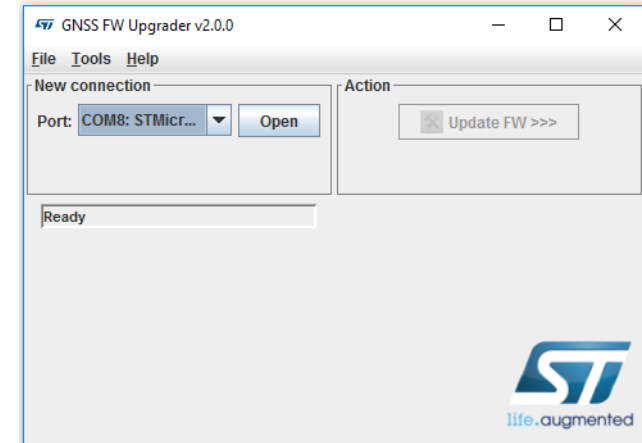

4

After selecting the right serial port, click **Open** to start a connection with your STM32 Nucleo and X-NUCLEO-GNSS1A1 expansion boards.

5

If the FW version on the Teseo-LIV3F module is not the latest one, click the **Update FW >>>** button to start the firmware upgrading process.

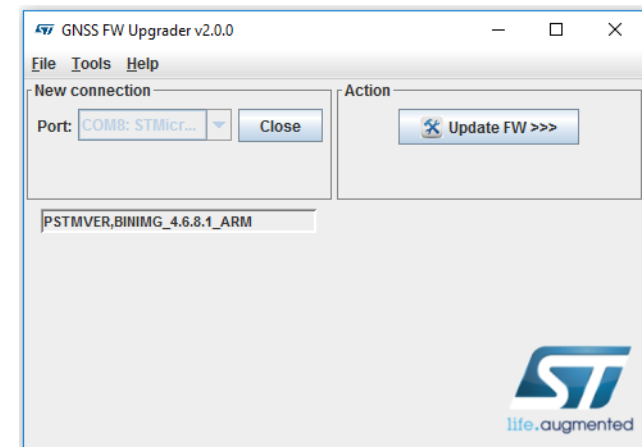

Evaluate Teseo-LIV3F using X-CUBE-GNSS1 and Teseo-Suite

1

- Download and install on your PC the ST Teseo-Suite software tool from st.com

2

- Connect the STM32 Nucleo board and the X-NUCLEO-GNSS1A1 expansion board
- Connect the GPS/GLONASS antenna to the connector on the X-NUCLEO-GNSS1A1 expansion board
- Connect the STM32 Nucleo board to your PC

3

- ✓ X-CUBE-GNSS1
 - └─ _htmresc
 - > Documentation
 - > Drivers
 - > Middlewares
 - ✓ Projects
 - └─ Multi
 - └─ Applications
 - > FW_Updater
 - > GetPos
 - > SimOSGetPos
 - ✓ Virtual_COM_Port
 - └─ Binary
 - > EWARM
 - └─ Inc
 - > MDK-ARM
 - └─ Src
 - > SW4STM32
- > Utilities

From X-CUBE-GNSS1 software resource package drag and drop Virtual_COM_Port_*.bin (in Binary folder) on Nucleo drive

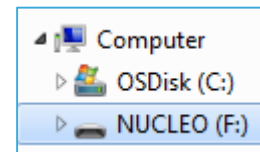

4

- Launch the ST Teseo-Suite on your PC
- To start managing, configuring and evaluating the Teseo GNSS device follow the Quick Training Guide available at the Teseo-Suite web page on st.com

All documents are available in the DESIGN tab of the related products webpage

X-NUCLEO-GNSS1A1:

- Gerber files, BOM, and schematics
- **DB3458:** GNSS expansion board based on Teseo-LIV3F module for STM32 Nucleo – **Data brief**
- **UM2327:** Getting started with X-NUCLEO-GNSS1A1 Global Navigation Satellite System expansion board based on Teseo-LIV3F module for STM32 Nucleo – **User Manual**

X-CUBE-GNSS1:

- **DB3444:** Global navigation satellite system software expansion for STM32Cube – **Data brief**
- **UM2334:** Getting started with the X-CUBE-GNSS1 Global Navigation Satellite System software expansion for STM32Cube – **User Manual**
- **Software setup file**

Consult www.st.com for the complete list

Quick Start Guide Contents

15

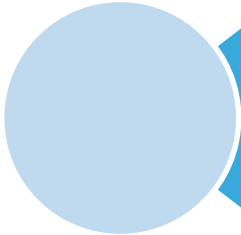

X-NUCLEO-GNSS1A1: STM32 Nucleo GNSS expansion board
Hardware and Software overview

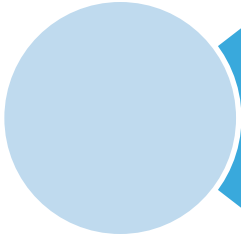

Setup & Demo Examples
Documents & Related Resources

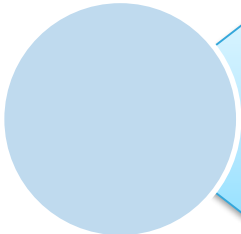

STM32 Open Development Environment: Overview

STM32 Open Development Environment

Fast, affordable Prototyping and Development

- The STM32 Open Development Environment (ODE) consists of a set of stackable boards and a modular open SW environment designed around the STM32 microcontroller family.

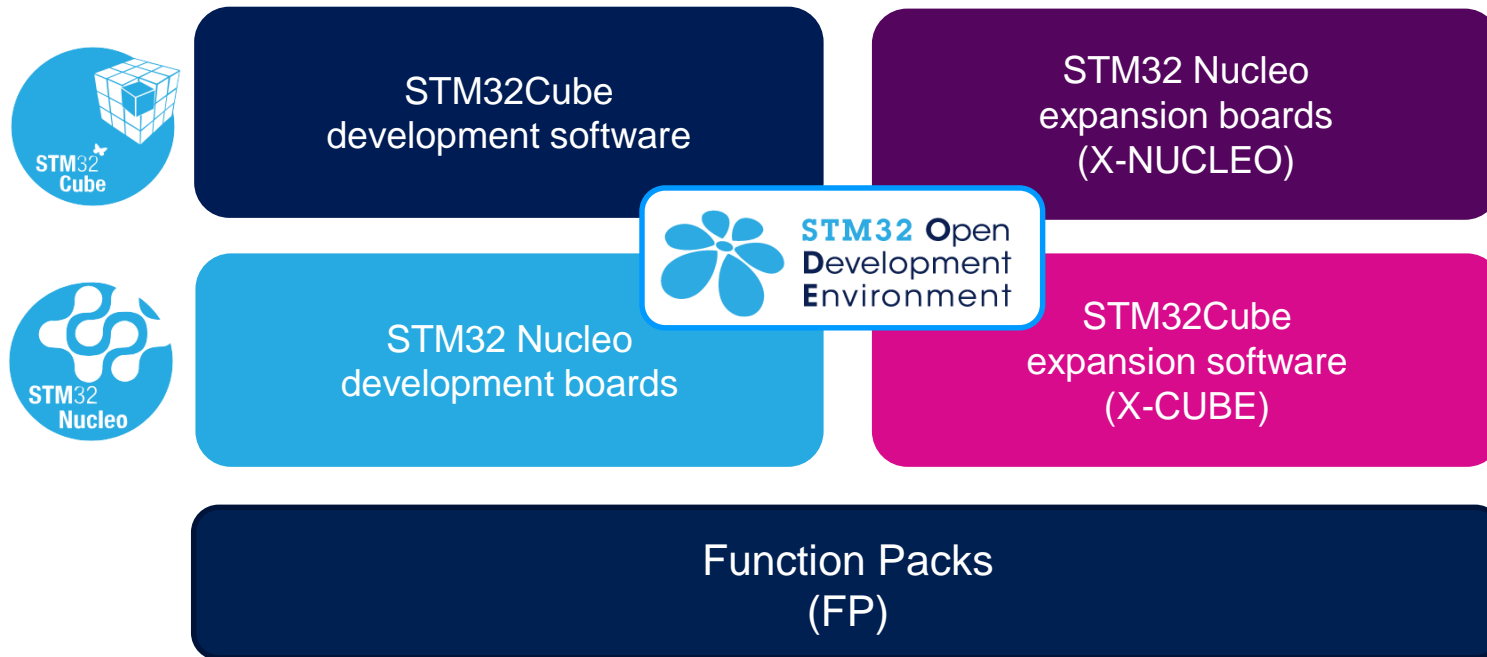

STM32 Nucleo Development Boards (NUCLEO)

- A comprehensive range of affordable development boards for all the STM32 microcontroller series, with unlimited unified expansion capabilities and integrated debugger/programmer functionality.

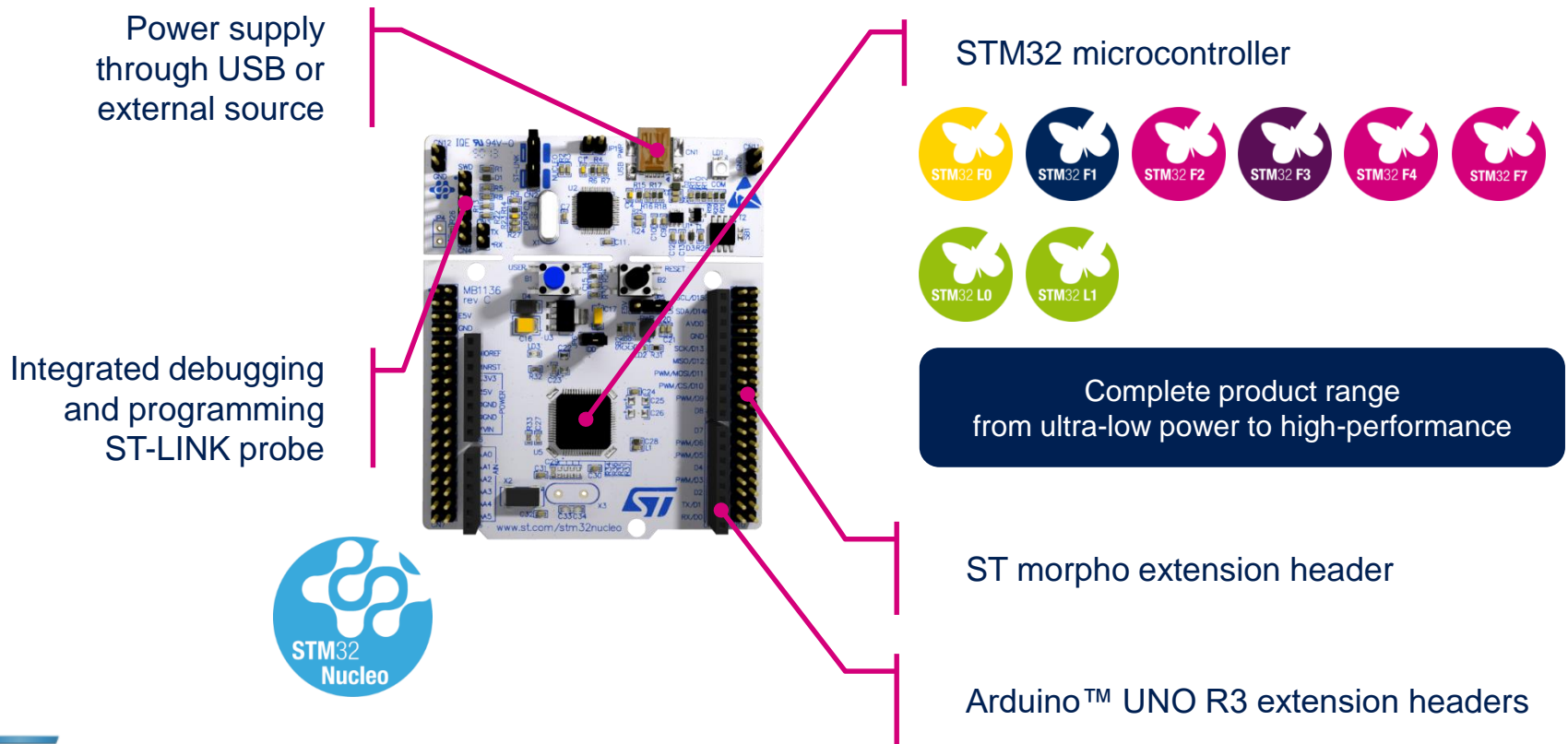

STM32 Nucleo Expansion Boards (X-NUCLEO)

- Boards with additional functionality that can be plugged directly on top of the STM32 Nucleo development board directly or stacked on another expansion board.

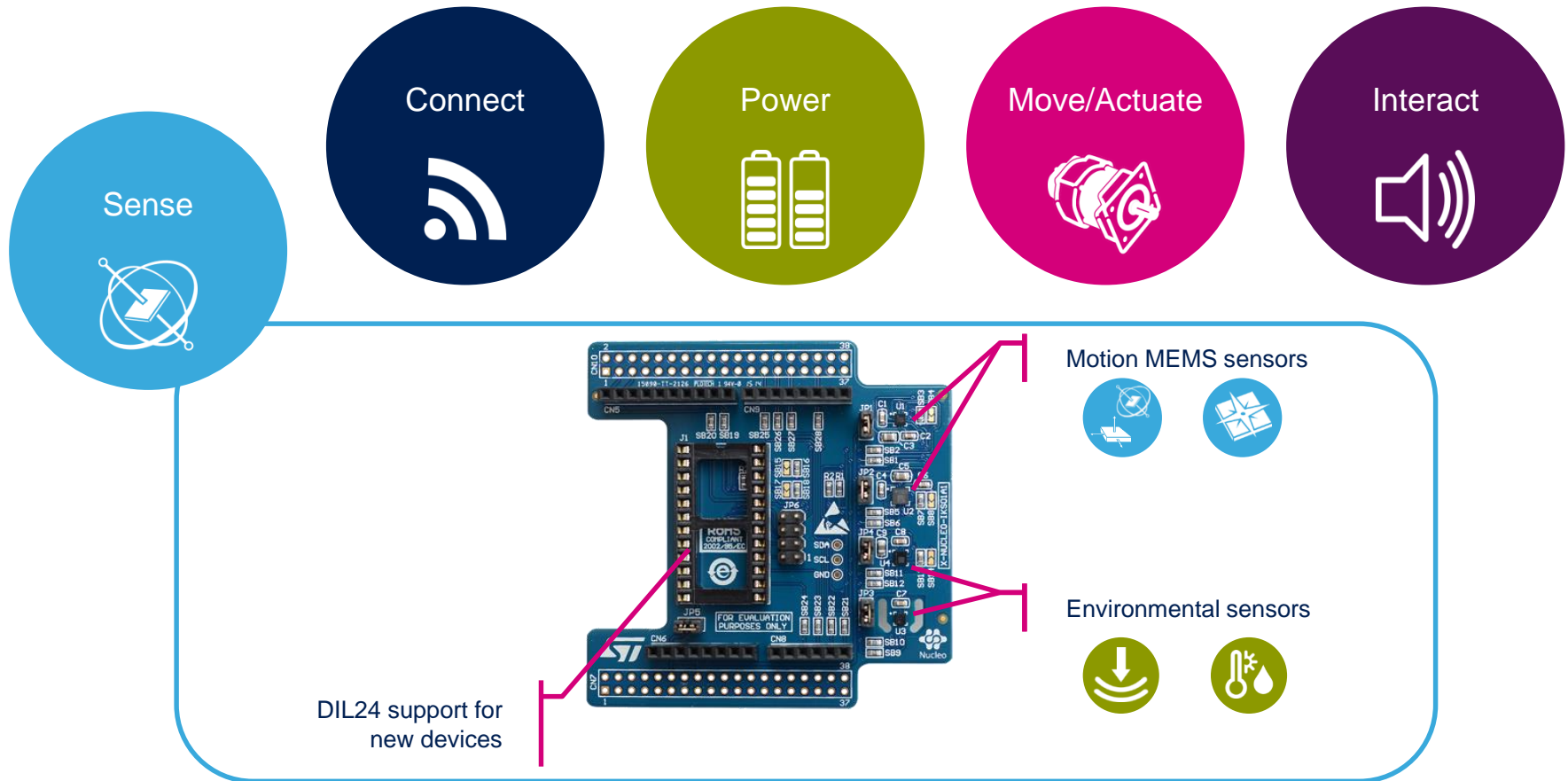

DIL24 support for new devices

Example of STM32 expansion board (X-NUCLEO-IKS01A1)

STM32 Open Development Environment

Software components

- **STM32Cube software (CUBE)** - A set of free tools and embedded software bricks to enable fast and easy development on the STM32, including a Hardware Abstraction Layer and middleware bricks.
- **STM32Cube expansion software (X-CUBE)** - Expansion software provided free for use with the STM32 Nucleo expansion board and fully compatible with the STM32Cube software framework. It provides abstracted access to expansion board functionality through high-level APIs and sample applications.

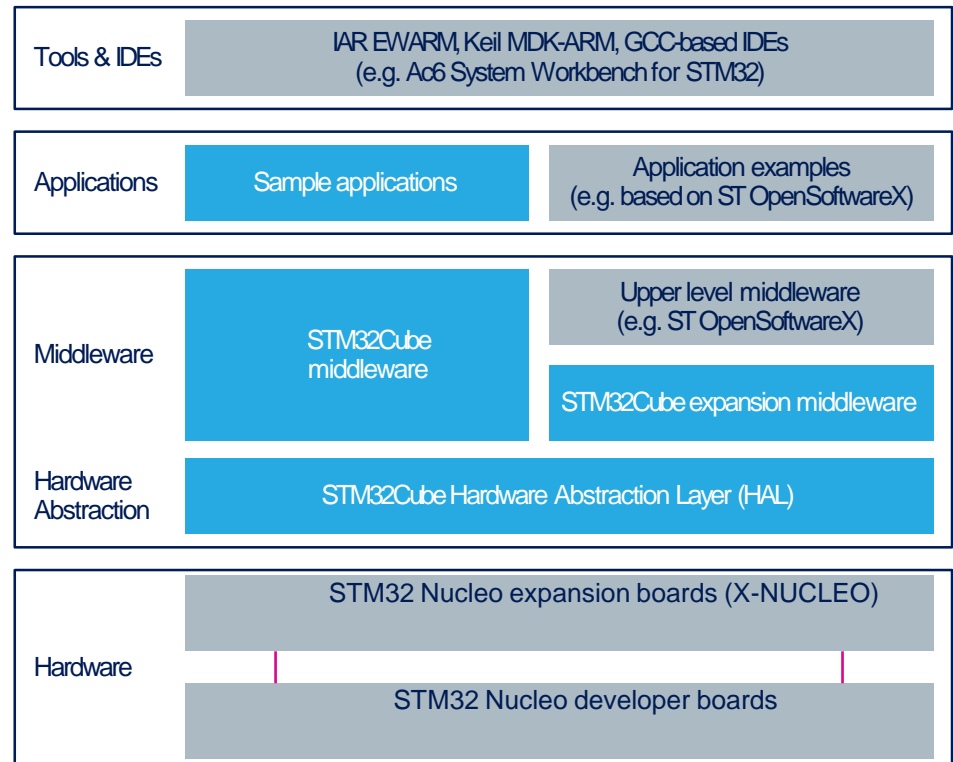

- **Compatibility with multiple Development Environments** - The STM32 Open Development Environment is compatible with a number of IDEs including IAR EWARM, Keil MDK, and GCC-based environments. Users can choose from three IDEs from leading vendors, which are free of charge and deployed in close cooperation with ST. These include Eclipse-based IDEs such as Ac6 System Workbench for STM32 and the MDK-ARM environment.

STM32 Open Development Environment

Building block approach

20

The building blocks

Your need

Our answer

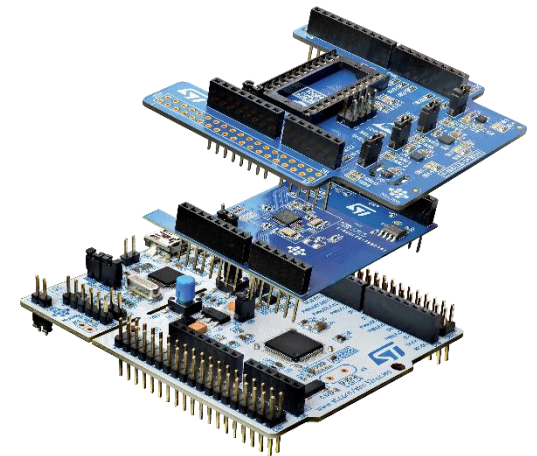
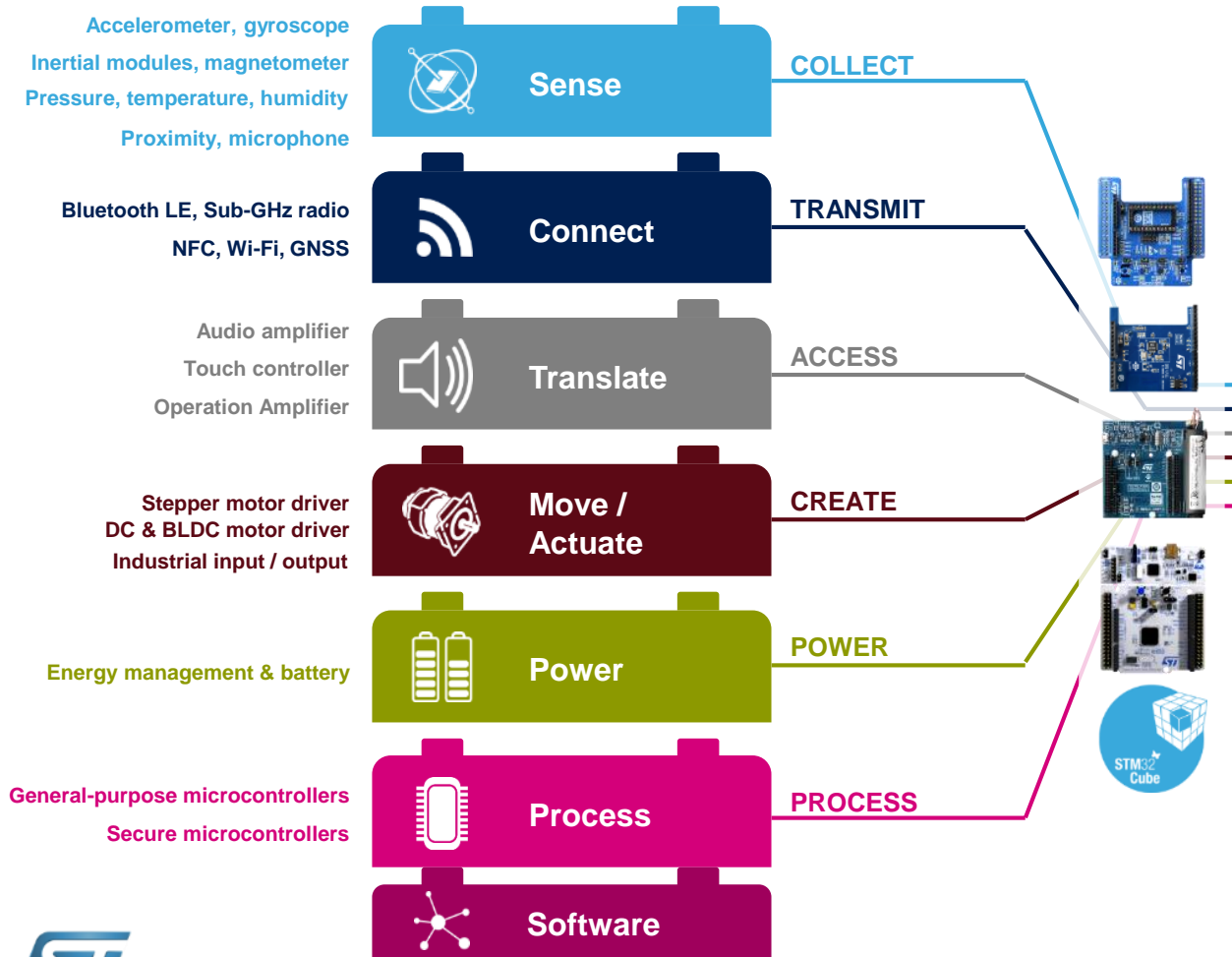

www.st.com/stm32code