

LOC		DIST		P		F		ZONE		LTR		REVISIONS			
AD	25											DESCRIPTION	DATE	APPD	
												D	EC 0010-1491-95	4/1/96	CR
												E	REV PER EC 0512-0016-03	09JAN04	AS

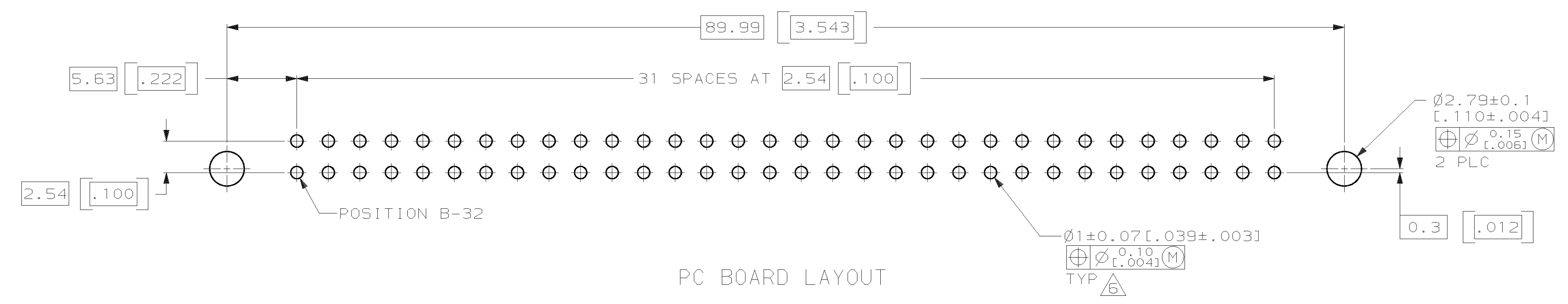
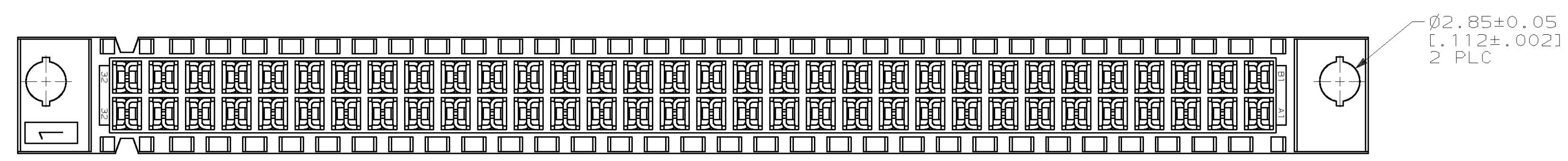
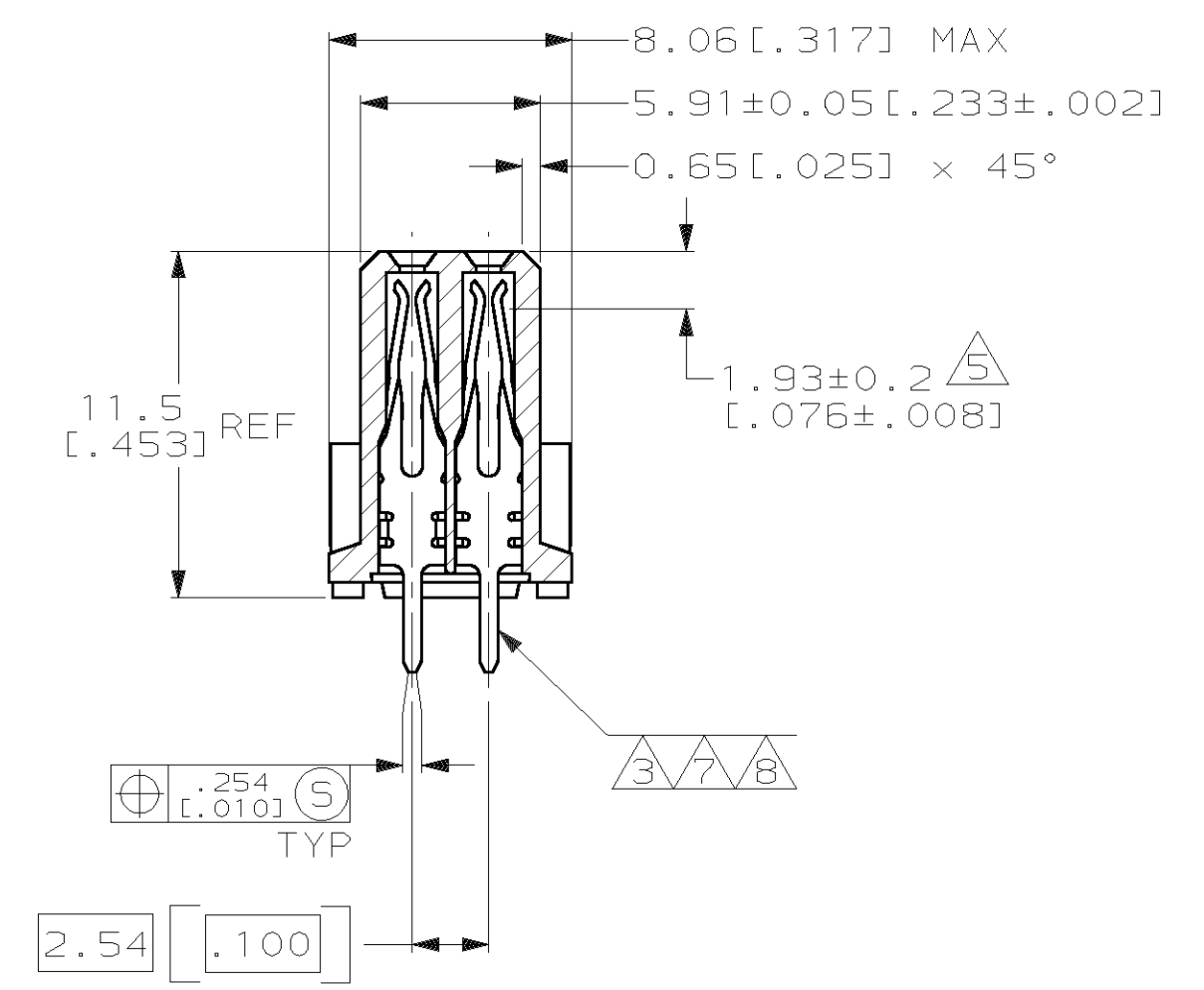
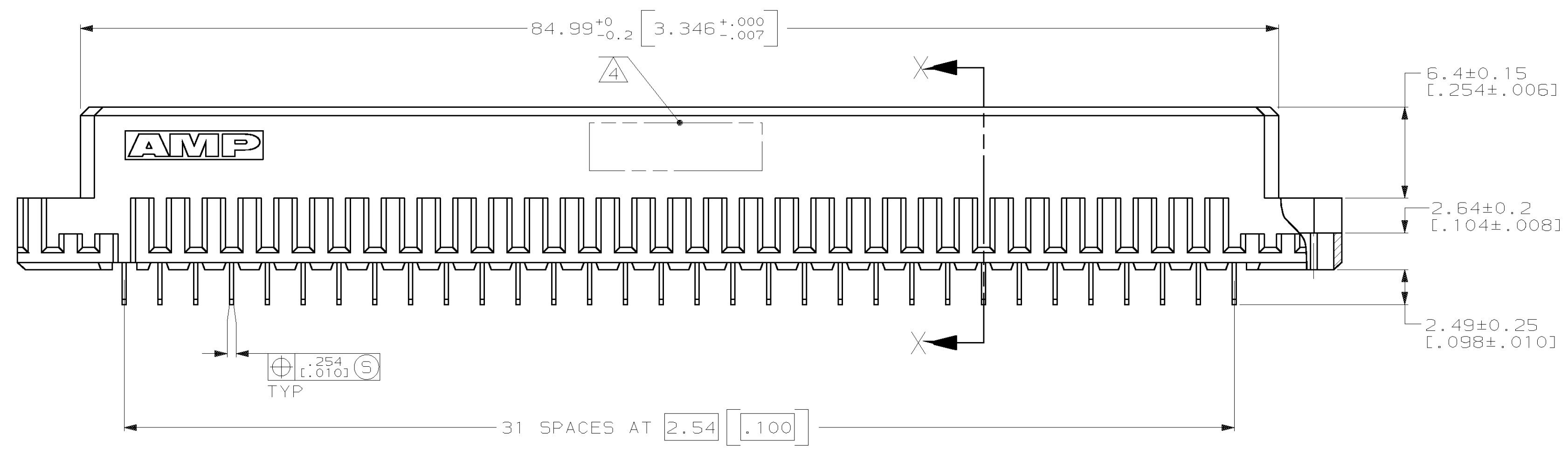
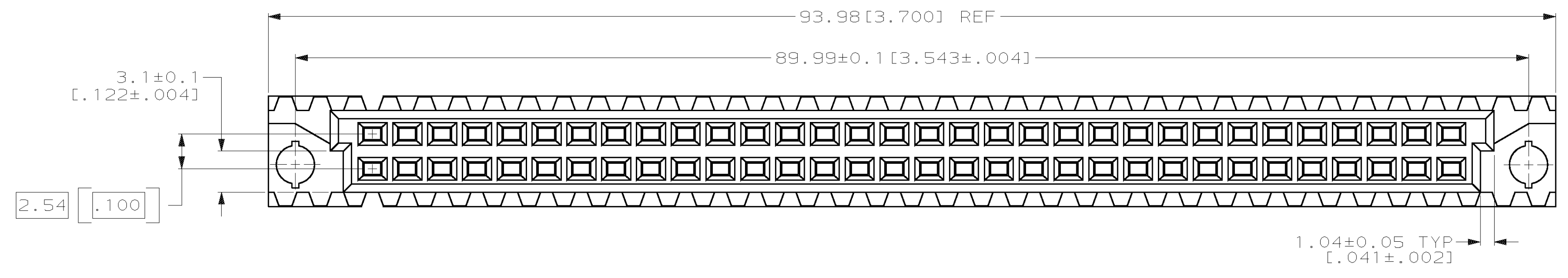

SECTION X-X

NOTE	POSITIONS LOADED	B	A	NO. OF LOADED POSITION	ASSY PART NUMBER
<b>OBSOLETE</b>	1 THRU 32	X	X	64	650859-9
	1 THRU 32	X	X	64	650859-5
<b>SUPERSEDED BY 650859-5</b>	1 THRU 32	X	X	64	650859-4

DO NOT SCALE PRINT. UNLESS SPECIFIED DIMENSIONS IN mm [INCHES]. TOLERANCES ON: 1 PLC DEC ± - 2 PLC DEC ± 0.13 [.005] ANGLES ± -	DR L. BRINER 6/27/90 CHK J. BROWN 7/18/90 APPD J. BROWN 7/18/90 MATERIAL HSG CONT	DR K.R. PARMER 7/19/90 PRODUCT SPEC - FINISH APPLICATION SPEC WEIGHT -	SIZE D 00779 SCALE 4:1	DRAWING NO 650859 SHEET 1 OF 1
--	---	---	---------------------------	-----------------------------------

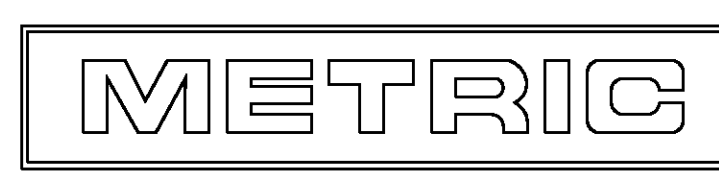

**AMP** | AMP INCORPORATED  
 Harrisburg, Pa. 17105  
 NAME  
**RECEPTACLE ASSEMBLY, EUROCARD,  
 TYPE B**