

Description	Material	Finish
Body	Brass	Nickel
Socket	BE CU	Gold
Insulation	PTFE	N/A
Gasket	SI Rubber	Rubber
Crimp Ring	Brass	Nickel
Heat Shrink	Polyolefin	Black

REVISIONS			
REV	DESCRIPTION	DATE	APPV
B	Updated footprint and dimensions; Added new title block	2-JUL-12	SAH

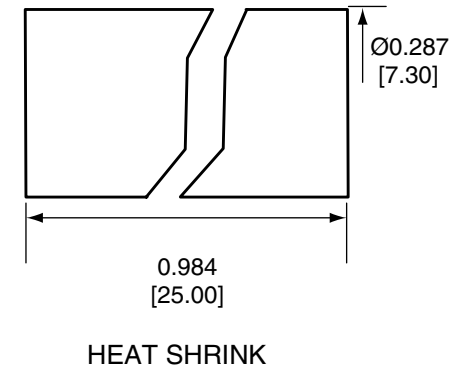
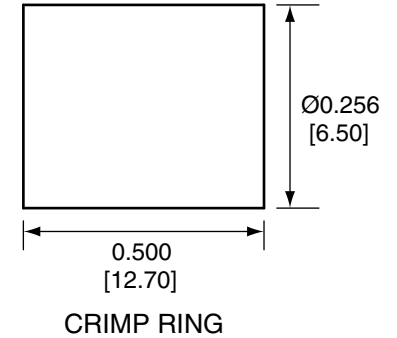
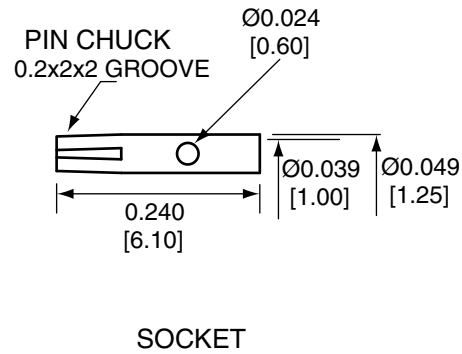
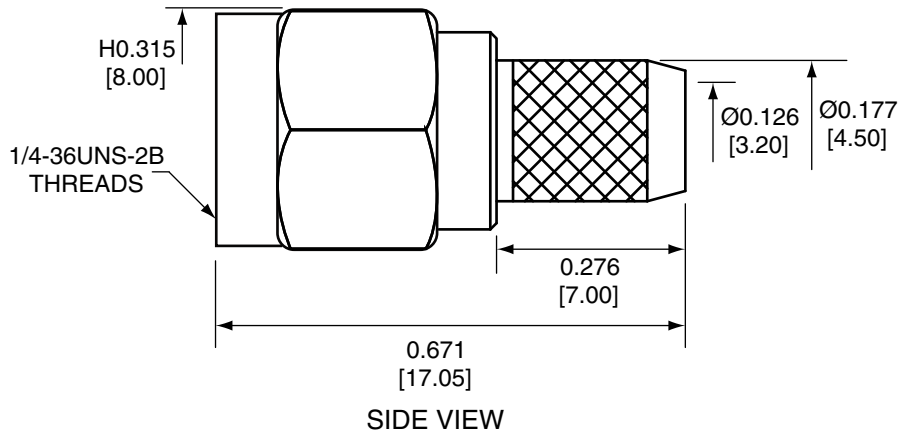

### CONREVSMA007-R58 ASSEMBLY INSTRUCTIONS

1. Strip cable to recommended dimensions.
2. Slip heat shrink and crimp ring over stripped cable.
3. Solder the socket to the center conductor.
4. Insert the socket, center conductor, and insulator into the body until the top of the socket is even with the white insulation in the body.
5. Wrap the braid around the tail of the body and crimp the ring with a 0.213" hex crimp tool (or one labeled for use with RG-58 cable).
6. Use heat shrink to cover crimp.

NOTES: (UNLESS OTHERWISE SPECIFIED)

1. ALL DIMENSIONS ARE IN INCHES [mm].
2. DIMENSIONS APPLY AFTER FINISHING.
3. MANUFACTURE TO BE COMPLIANT WITH EU RoHS DIRECTIVE.
4. SAFETY BREAK ALL SHARP CORNERS AND EDGES .02 MAXIMUM.

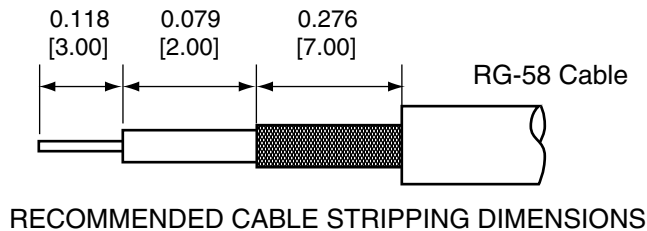

**WARNING:** THIS DRAWING CONTAINS PROPRIETARY INFORMATION THAT IS THE SOLE PROPERTY OF LINX TECHNOLOGIES, AND SHALL BE TREATED AS SUCH. NO DISCLOSURE OR REPRODUCTION OF THIS DOCUMENT IS PERMITTED, IN WHOLE OR IN PART, WITHOUT THE EXPRESS WRITTEN PERMISSION OF LINX TECHNOLOGIES OR ITS DESIGNATED AGENTS.

MATERIAL:	TOLERANCES: .020 [0.50]-.200 [5.00]= ±.008 [0.20] .200 [5.00]-1.200 [30.00]= ±.016 [0.40] 1.20 [30.0]-4.75 [120.0]= ±.024 [0.60] 4.75 [120.0]-12.40 [315.0]= ±.040 [1.0]	PROJECTION: 
FINISH:	DRAWN: B.MURPHY	DT: 2-JUL-12
	ENGR: S.HOGAN	DT: 2-JUL-12

		159 ORT LANE MERLIN, OR 97532	
TITLE: <b>RP-SMA MALE CABLE END CRIMP FOR RG-58 CABLE</b>			
SIZE <b>A</b>	DWG. NO. <b>CONREVSMA007-R58</b>	REV <b>B</b>	
SCALE: 2:1	DO NOT SCALE DRAWING	SHEET 1 OF 1	