

NOTE:  
 UNIT IS SUPPLIED WITH A 7.00 [177.8] DIA.  
 0-100 GRADUATED DIAL PLATE FOR PANEL MOUNTING.

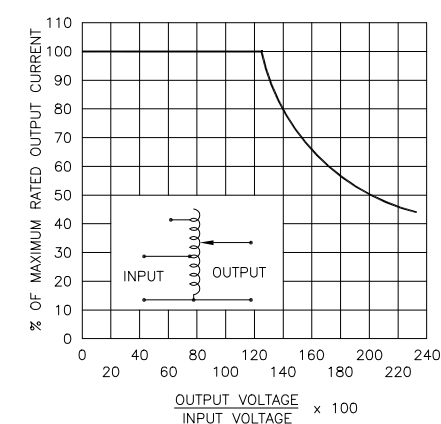
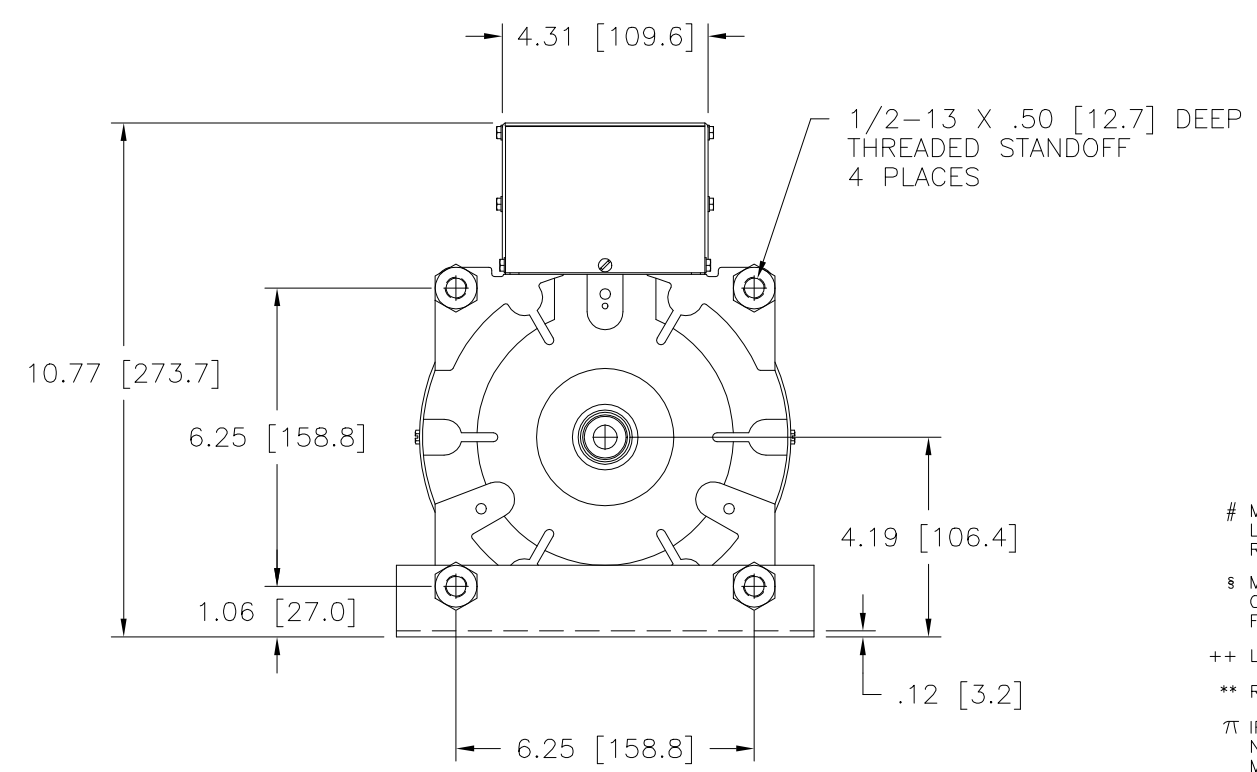

# MAXIMUM OUTPUT CURRENT IN OUTPUT VOLTAGE RANGE FROM 0 TO 25% ABOVE LINE VOLTAGE. AT HIGHER OUTPUT VOLTAGES, THE OUTPUT CURRENT MUST BE REDUCED ACCORDING TO THE DERATING CURVE FIGURE A.  
 § MAXIMUM KVA AT MAXIMUM OUTPUT VOLTAGE AND CORRESPONDING DERATED OUTPUT CURRENT. MAXIMUM KVA FOR LOWER VOLTAGES MAY BE CALCULATED FROM DERATING CURVE FIGURE A.  
 ++ LINE TO LINE VOLTAGE.  
 \*\* REQUIRES ONE 52LAC PARALLELING CHOKE (NOT SUPPLIED).  
 ∇ IF GANGED UNITS ARE USED IN A SYSTEM THAT ORDINARILY HAS A COMMON NEUTRAL OR GROUND BETWEEN SOURCE AND LOAD, THE NEUTRAL OR GROUND MUST BE CONNECTED TO THE COMMON TERMINALS OF THE VARIABLE TRANSFORMER ASSEMBLY. IF THE SYSTEM HAS NO NEUTRAL, THE LOAD MUST BE BALANCED OR THE TRANSFORMER WILL BE DAMAGED.  
 ■ JUMPER PROVIDED IN STANDARD COMMON POSITION AND SHOULD BE MOVED OR REMOVED AS REQUIRED.

SPECIFICATIONS											
WIRING	INPUT		OUTPUT				SHAFT ROTATION TO INCREASE VOLTAGE	TERMINAL CONNECTIONS			
	VOLTS	HERTZ	VOLTS	CONSTANT CURRENT LOAD		CONSTANT IMPEDANCE LOAD		FOR INCREASING VOLTAGE AS VIEWED FROM BASE END ■			
				MAX. AMPS	MAX. KVA	MAX. AMPS		MAX. KVA	INPUT	JUMPER	OUTPUT
SINGLE PHASE PARALLEL **	240	50/60	0-240	20	4.80	26	6.20	CW	2-2,4-4	---	4-B
			0-280	20	5.60	---	---	CCW	2-2,4-4	---	2-B
	120	50/60	0-280	20#	2.40 §	---	---	CW	1-1,4-4	---	4-B
			0-280	20#	2.40 §	---	---	CCW	5-5,2-2	---	2-B
SINGLE PHASE SERIES	480	50/60	0-480	10	4.80	13	6.24	CW	2-2	4-4	3-3
			0-560	10	5.60	---	---	CCW	4-4	2-2	3-3
	240	50/60	0-560	10#	2.40 §	---	---	CW	1-1	4-4	3-3
			0-560	10#	2.40 §	---	---	CCW	5-5	2-2	3-3
THREE PHASE OPEN DELTA ∇	240	50/60	0-240	10	4.20	13	5.40	CW	2-4-2	4-4	3-4-3
			0-280	10	4.85	---	---	CCW	4-2-4	2-2	3-2-3
	120	50/60	0-280	10#	2.10 §	---	---	CW	1-4-1	4-4	3-4-3
			0-280	10#	2.10 §	---	---	CCW	5-2-5	2-2	3-2-3

UNLESS OTHERWISE SPECIFIED, TOLERANCE IS # DECIMALS .XX .XXX .005 HOLES .01 ANGLES 1° DRAFT 1-1/2° UNITS IN [mm]

MATERIAL: ALL DIMENSIONS APPLY AFTER PLATING

THE INFORMATION AND DESIGN DISCLOSED HEREIN WAS ORIGINATED BY AND IS THE PROPERTY OF STACO ENERGY PRODUCTS CO., WHICH RESERVES ALL PATENT, PROPRIETARY, DESIGN, MANUFACTURING, REPRODUCTION, USE AND SALE RIGHTS THEREOF, AND TO ANY ARTICLE DISCLOSED THEREIN EXCEPT TO THE EXTENT RIGHTS ARE EXPRESSLY GRANTED TO OTHERS. THE FOREGOING DOES NOT APPLY TO VENDOR PROPRIETARY PARTS.

DATE 12/18/98  
 DRAWN BY S.A. SMITH  
 CHECKER  
 ENGINEER

DATE  
 SCALE .50=1  
 SHEET 1 OF 1

DO NOT SCALE DWG.  
 CODE IDENT. NO. 83008  
 DWG. NO. 031-5513

CUSTOMER APPROVAL DATE

STACO ENERGY PRODUCTS CO.  
 A COMPONENTS CORPORATION OF AMERICA COMPANY  
 DAYTON, OHIO U.S.A.